



SDJ Bearing Housings

SDJ type bearing housings are very large and heavy duty plummer block housings.

Heavy ribbed construction in the bottom half permits SDJ housing to accommodate load acting at right angles to the foundation surface.

SDJ housings are preferred choice for steel industries, crusher application and cement industries.

SDJ housings are split plummer blocks suitable for spherical roller bearing of 231 series on adapter sleeve, however it is possible to modify the housings to accommodate bearings of other series.

SDJ housings can be supplied with end covers for closed shaft application. They are available for locating and non-locating bearing arrangement. SDJ housings are designed for grease lubrication. The recommended initial grease fill for each size is specified in the table. A suitable grease nipple is provided on each housing.

Modified SDJ housings can also be supplied for oil-lubrication application.

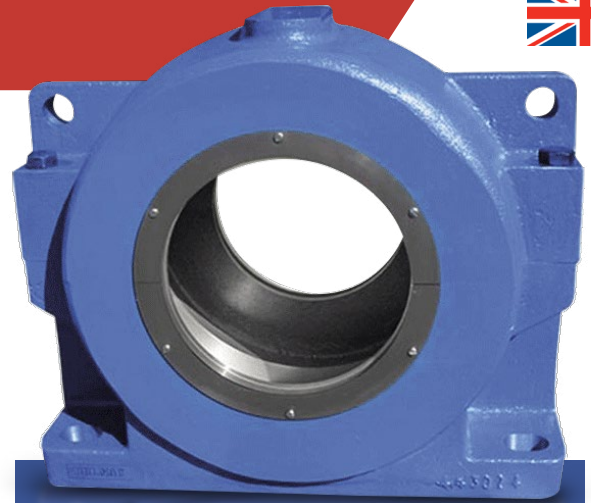

SUPPLEMENTARY DESIGNATIONS:

Housings for bearing with adapter sleeve for plain cylindrical shaft	Standard
Housings for shaft end, with end cover	A
Housings for non-locating bearing	L
Housings for locating bearing	F
Housings with labyrinth seals	TS

SEALS:

Standard labyrinth seal are supplied with the housings. However, we can also supply special sealing configurations on request.

EYE BOLT:

For anchoring purpose sturdy holes are provided on the each side of housing, instead of eye bolt.

MATERIALS:

SDJ housings can be supplied in following materials.

- Cast steel **SDJS**
- High Grade grey cast iron **SDJC**
- Spheroidal graphite iron (Ductile Iron) **SDJD**

NOTE: it is important to specify the bearing housing requirement as-

- (1) **AL** Housings for shaft end, with end cover, for non-locating bearing.
- (2) **AF** Housings for shaft end, with end cover, for locating bearing.
- (3) **BL** Housings for through shaft, for non-locating bearing.
- (4) **BF** Housings for through shaft, for locating bearing.

“BEARING HOUSING SOLUTIONS – WORLDWIDE”



SDJ Plummer Block Housings for Special Spherical Roller Bearings with Adapter Sleeve

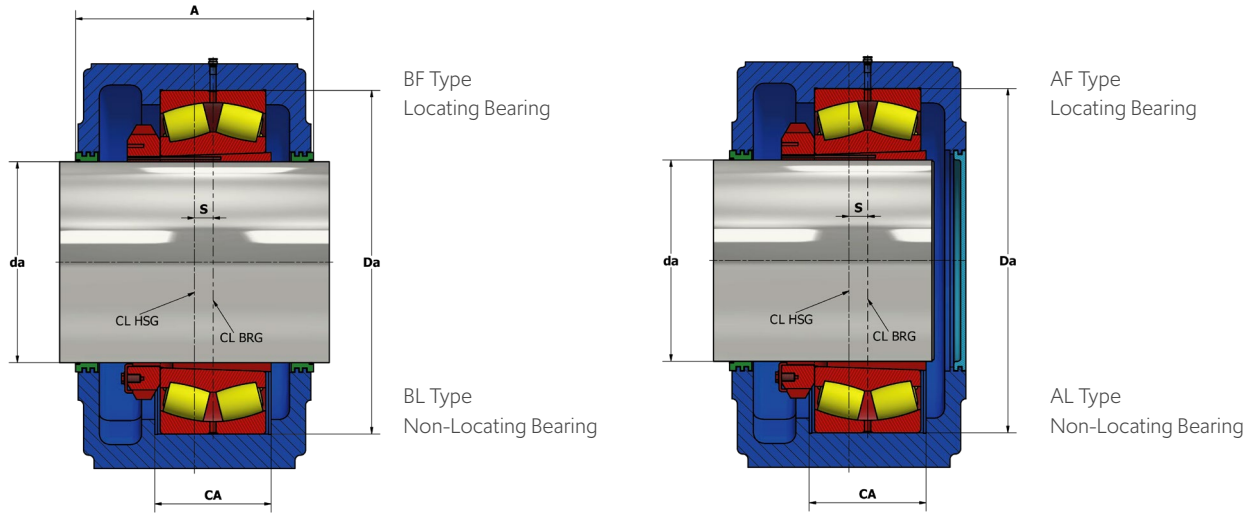

Shaft dia. (mm)	Housing Dimensions Measured in mm														Masses (Approx) Kg	Designations \$ Housing for through shaft	
	Da	A	A1	Ca	Da	H	H1	H2	J	J1	L	N	N1	S		G	Non-Locating Bearing
320	410	350	190	580	705	360	70	700	240	830	68	52	30	42	550	SDJC 3168 FTS	SDJC 3168 LTS
340	410	350	192	600	705	360	70	700	240	830	68	52	30	42	500	SDJC 3172 FTS	SDJC 3172 LTS
360	450	380	194	620	765	390	75	760	280	880	68	52	35	42	775	SDJC 3176 FTS	SDJC 3176 LTS
380	450	380	200	650	765	390	75	760	280	880	68	52	35	42	700	SDJC 3180 FTS	SDJC 3180 LTS
400	480	400	224	700	855	440	80	810	280	940	68	52	35	42	875	SDJC 3184 FTS	SDJC 3184 LTS
410	480	400	226	720	855	440	80	810	280	940	68	52	35	42	800	SDJC 3188 FTS	SDJC 3188 LTS
430	520	440	240	760	920	470	80	880	310	1040	80	60	35	48	1200	SDJC 3192 FTS	SDJC 3192 LTS
450	520	440	248	790	920	470	80	880	310	1040	80	60	35	48	1100	SDJC 3196 FTS	SDJC 3196 LTS

“BEARING HOUSING SOLUTIONS – WORLDWIDE”





SDJ Plummer Block Housings for Special Spherical Roller Bearings with Adapter Sleeve

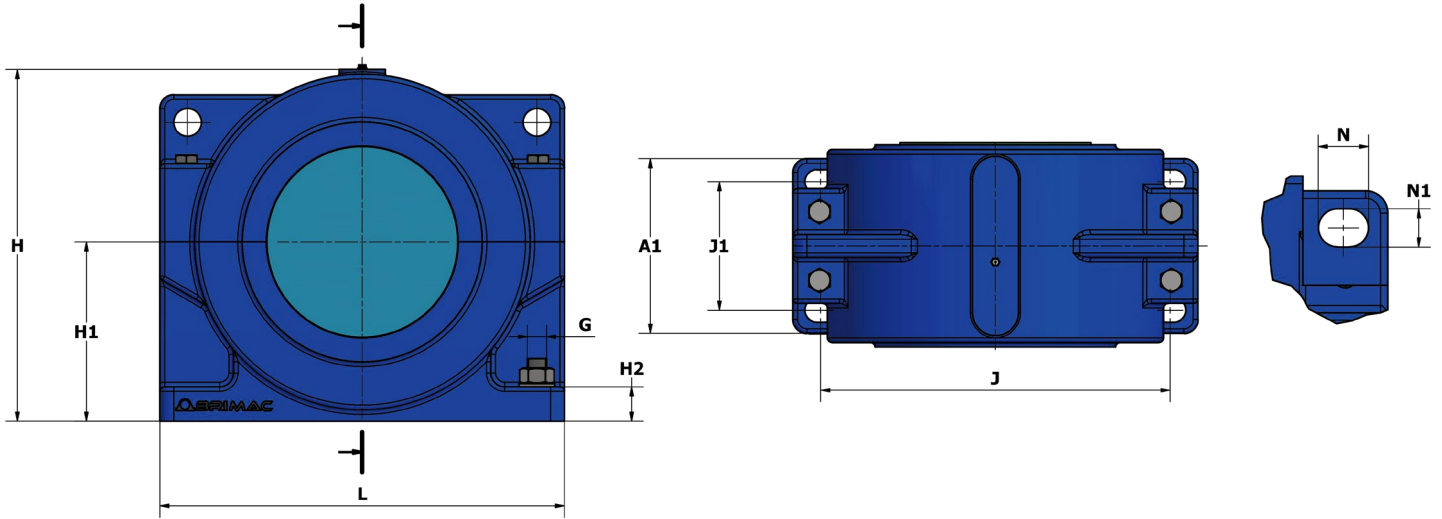

Shaft dia. (mm)	Appropriate Bearing	Adapter Sleeve	Separate components Housing without seals		Labyrinth Ring with O section tube	End cover with O section tube	Grease Quantity * Initial Fill (Kg)
			Locating Bearing	Non-Locating Bearing			
320	23168 CCK/W33	OH 3168 H	SDJC 3168 F	SDJC 3168 L	TS 68	ETS 68	19.3
340	23172 CCK/W33	OH 3172 H	SDJC 3172 F	SDJC 3172 L	TS72	ETS 72	19.1
360	23176 CCK/W33	OH 3176 H	SDJC 3176 F	SDJC 3176 L	TS 76	ETS 76	24.5
380	23180 CCK/W33	OH 3180 H	SDJC 3180 F	SDJC 3180 L	TS 80	ETS 80	23.8
400	23184 CCK/W33	OH 3184 H	SDJC 3184 F	SDJC 3184 L	TS 84	ETS 84	33.3
410	23188 CCK/W33	OH 3188 H	SDJC 3188 F	SDJC 3188 L	TS 88	ETS 88	33.0
430	23192 CCK/W33	OH 3192 H	SDJC 3192 F	SDJC 3192 L	TS 92	ETS 92	42.6
450	23196 CCK/W33	OH 3196 H	SDJC 3196 F	SDJC 3196 L	TS 96	ETS 96	40.4

“BEARING HOUSING SOLUTIONS – WORLDWIDE”